

Outline Dimensions (Units:mm)

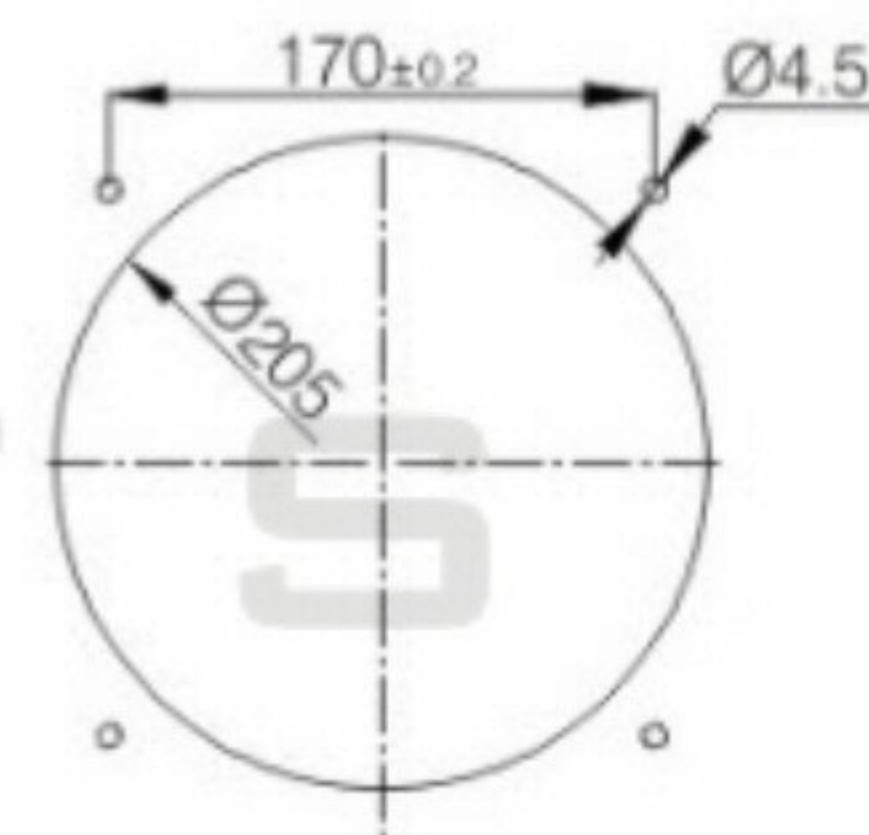

mounting dimension

- Ⓐ Rotation direction of blades : CCW seen from the front impellers
- Ⓑ Power Connection : PA-10 terminal connection
- Ⓒ Unit weight : 2.2kg

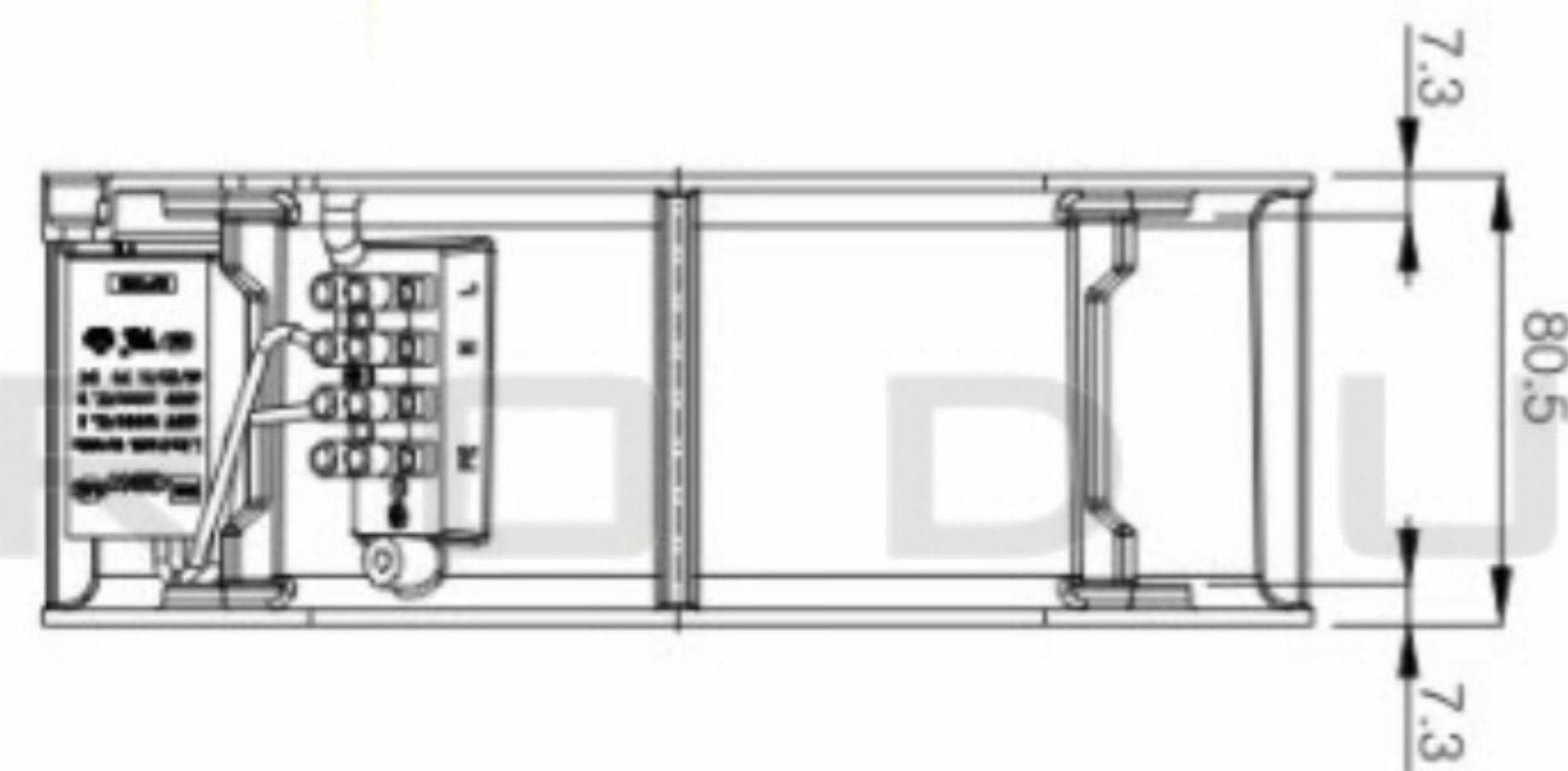
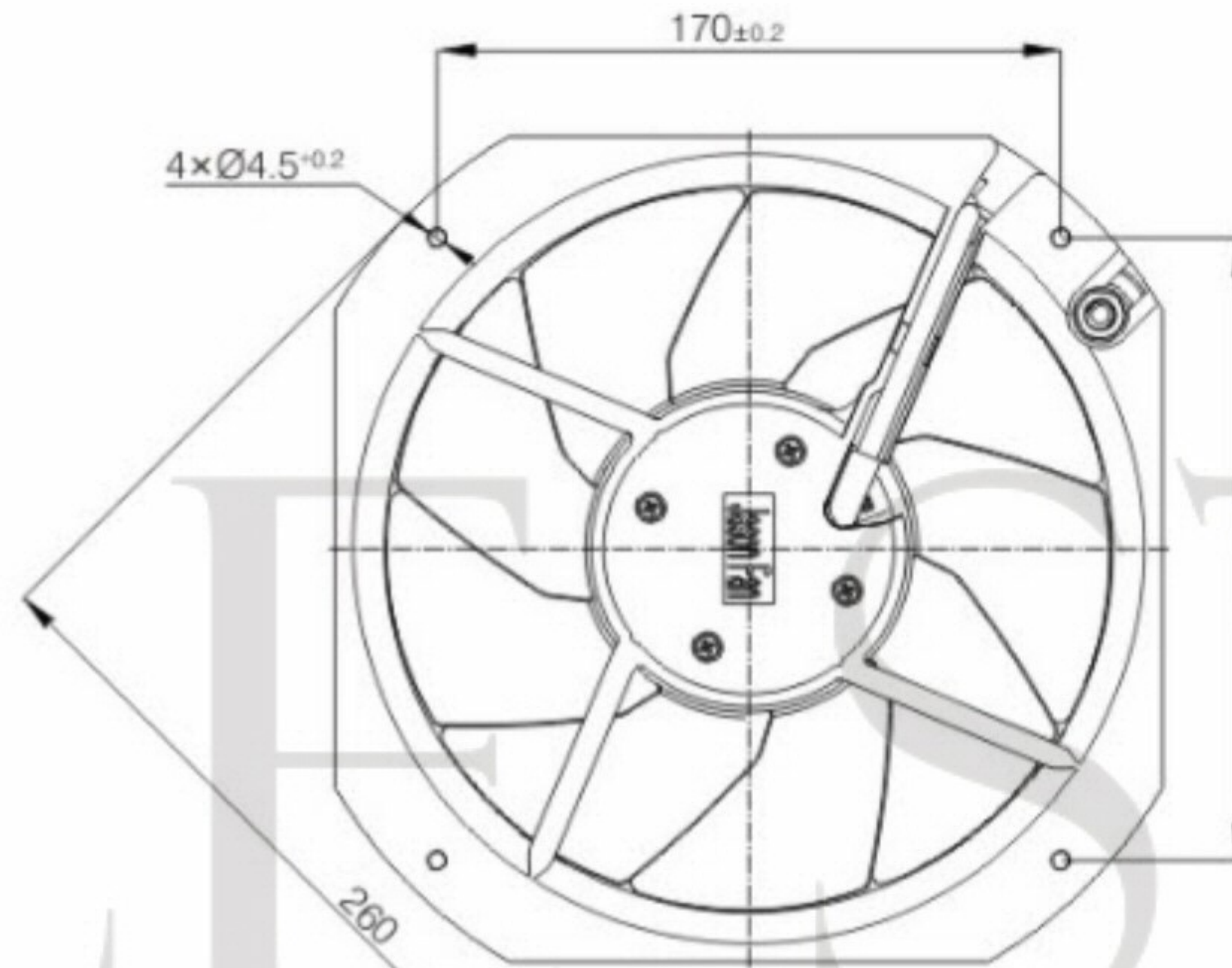
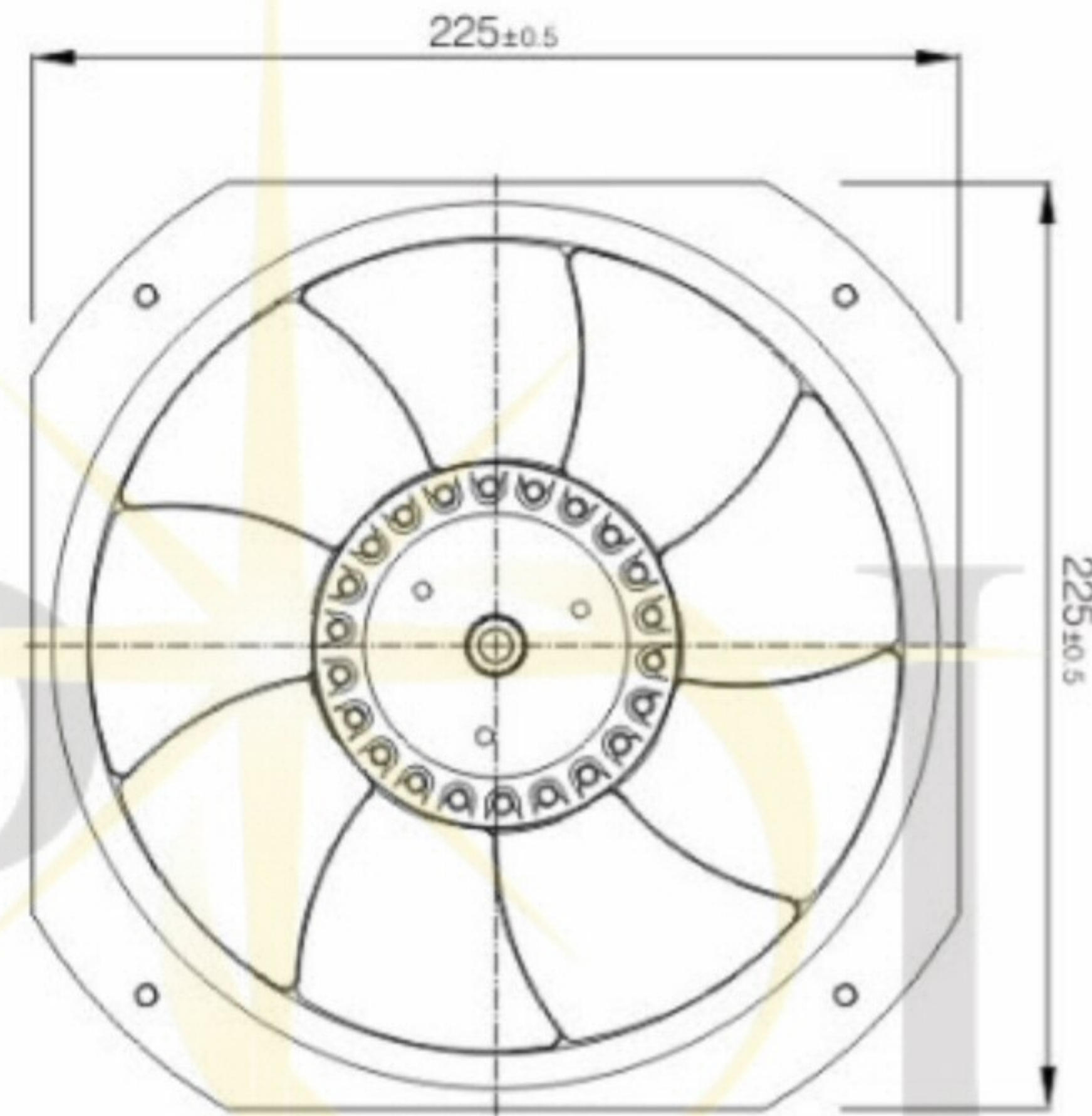
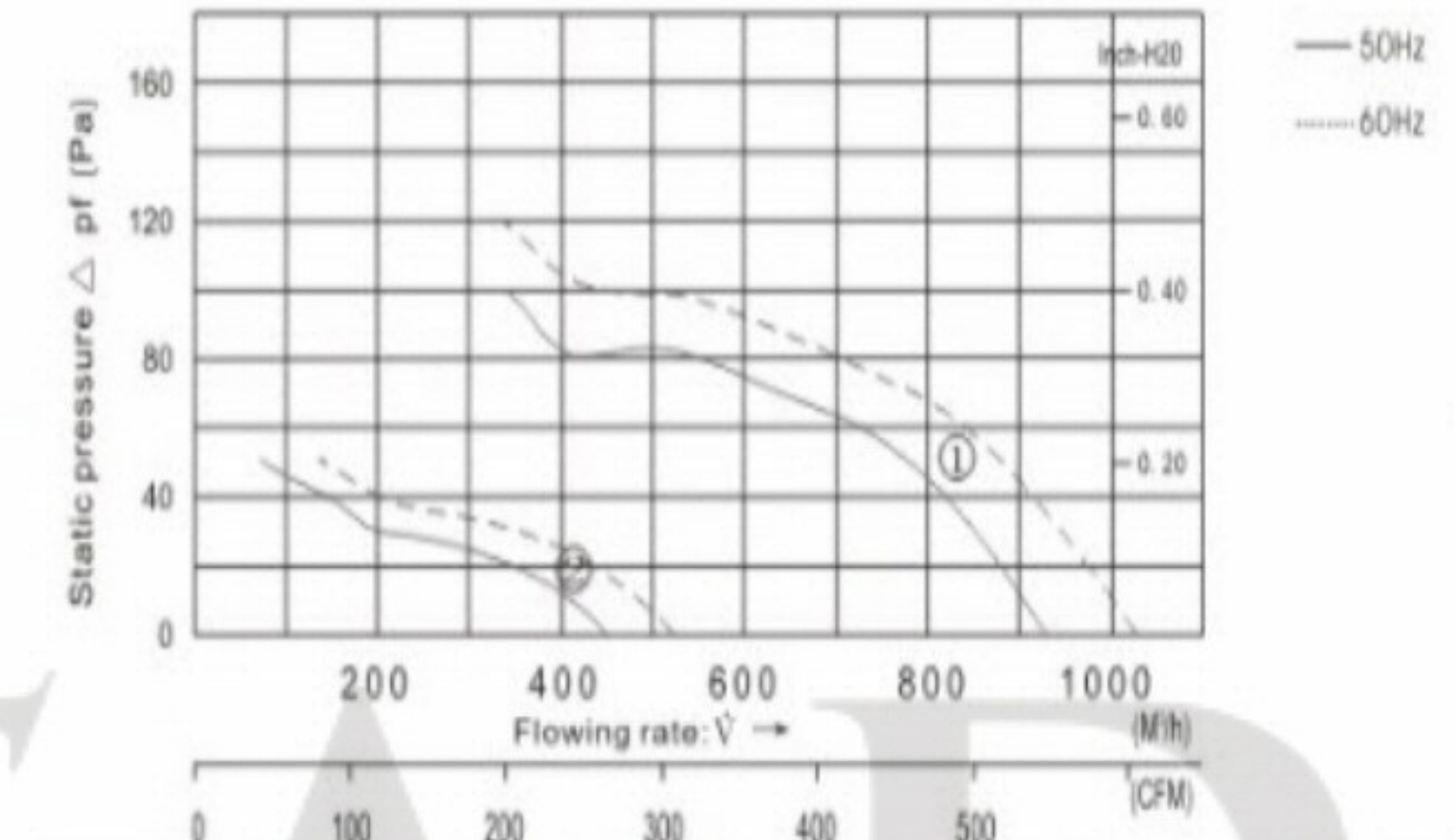

Type	Axial Flow Fan
Frame Material	Aluminum die-casting
Impeller	Metal
Motor Structure	External rotor motor
Protection	Automatic recovery thermal protector
Temperature & Humidity	-30°C ~ +80°C, 0% ~ 95%
Withstand Voltage	AC 1800V at 0.5mA 50/60Hz
Power connection	PA-10(Terminal block connection)
Protection Grade	IP44
Insulation System	F
Voltage	115VAC / 230VAC / 380VAC
Power	50/60Hz
Air Volume	546-596CFM
Speed	2550-2750RPM, Singel speed or 3-speed
Certification	CE, ROHS UL, CSA
Unit weight	2.2KG



SPECIFICATION					
Motor	AC	Speed (RPM)	2550-2750	Bearings	Ball
Voltage (V)	230	Motor Protection	Th.Prot.	Weight (Kg)	2.2
Frequency (Hz)	50/60	Insulation Class	F	Noise dB(A)	
Power In/Out (W)	65/77	Protection Class	IP44	Air Volume (cfm)	546~596
Current (A)					

POLE STAR
PRODUCTS LIMITED

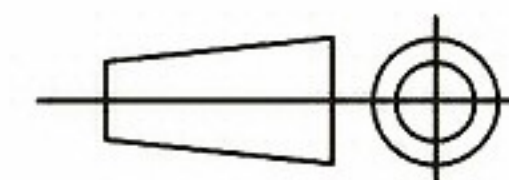
POLE STAR PRODUCTS LIMITED	
Product Code PS22580BT-3	
Projection Angle ± 3°	
	A4 Scale: Sheet: 1 of