

Accessories - DD7F (Mounting Feet)

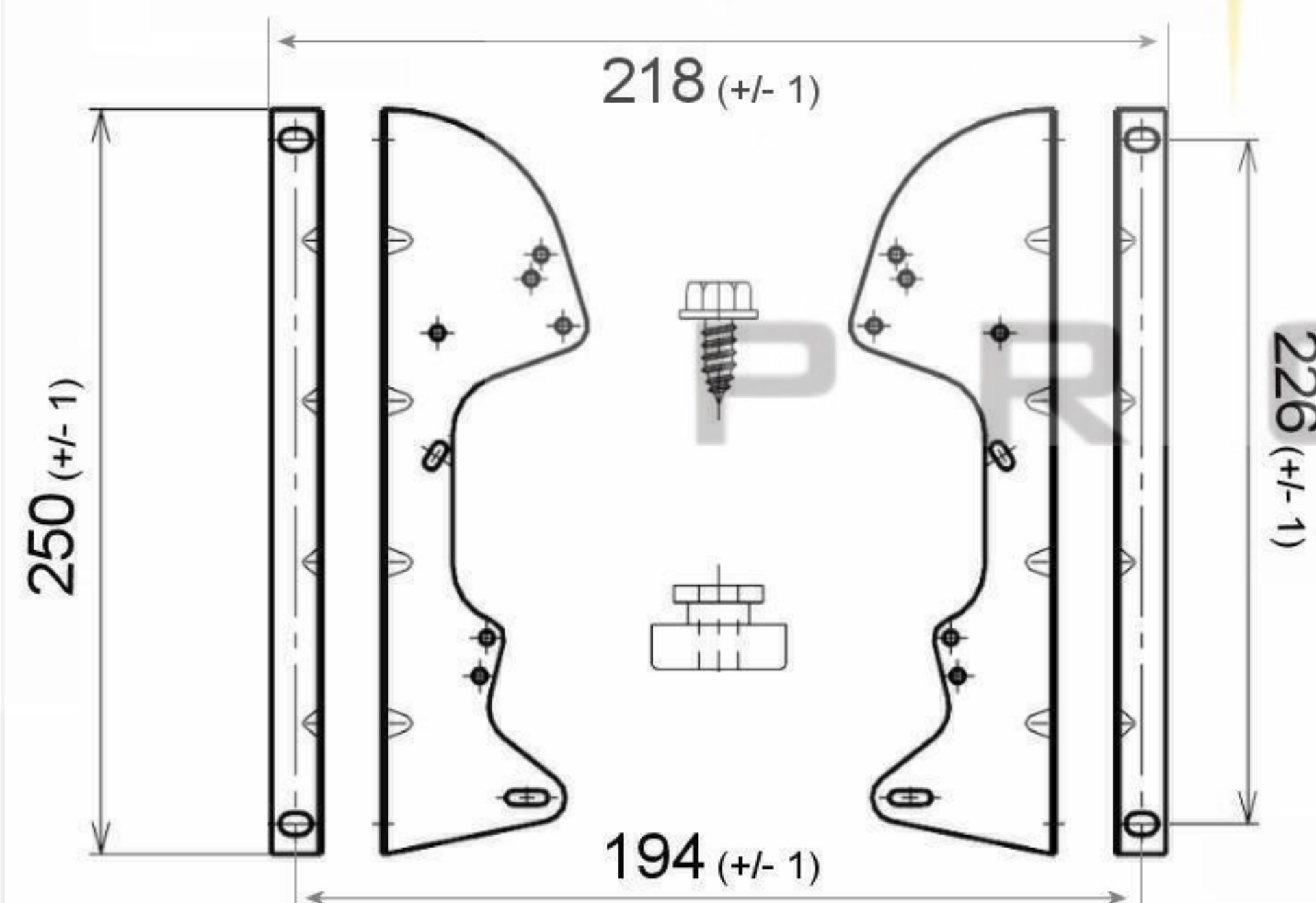

Accessories - DDF7/5 (Flange)

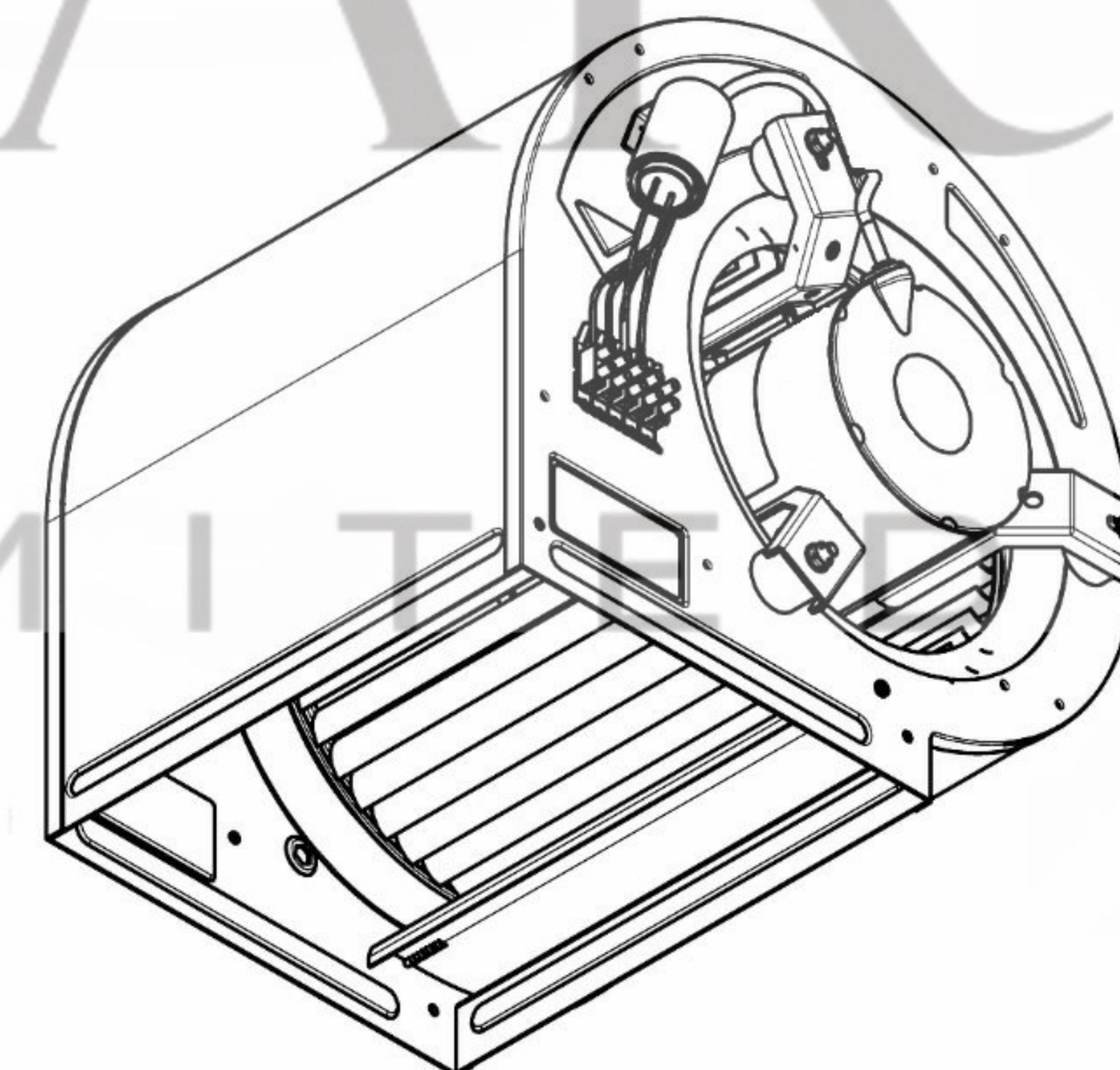
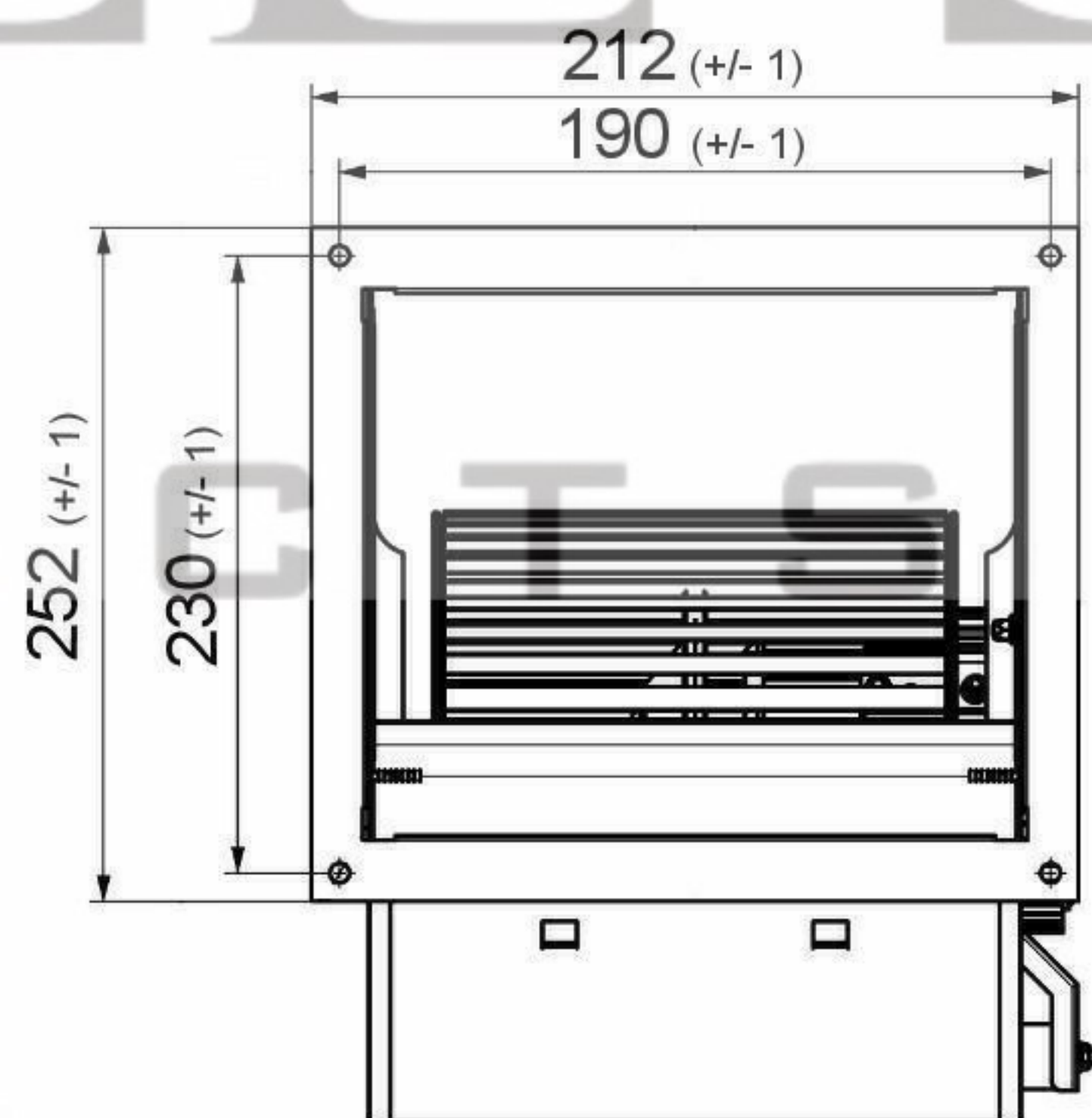

| SPECIFICATION | | | | | |
|------------------|---------|------------------|---------|--------------------------------|------|
| Motor | PSC | Speed (RPM) | 1250 | Bearings | Ball |
| Voltage (V) | 230/240 | Motor Protection | Th.Prot | Weight (Kg) | 8.0 |
| Frequency (Hz) | 50/60 | Insulation Class | B | Air Volume (M ³ /h) | 900 |
| Power In/Out (W) | 75 | Protection Class | IP42 | Noise Level (dBA) | |
| Current (A) | 0.67 | Capacitor (Mf) | 5.0 | Pressure (Pa) | 41 |

POLE STAR
PRODUCTS LIMITED

| | |
|----------------------------|-------------|
| POLE STAR PRODUCTS LIMITED | |
| Product Code | |
| DD7/5-F75/1V-1 | |
| Projection Angle | A4 |
| ± 3° | Scale: |
| | Sheet: 1 of |