

All measurements shown are in millimeters

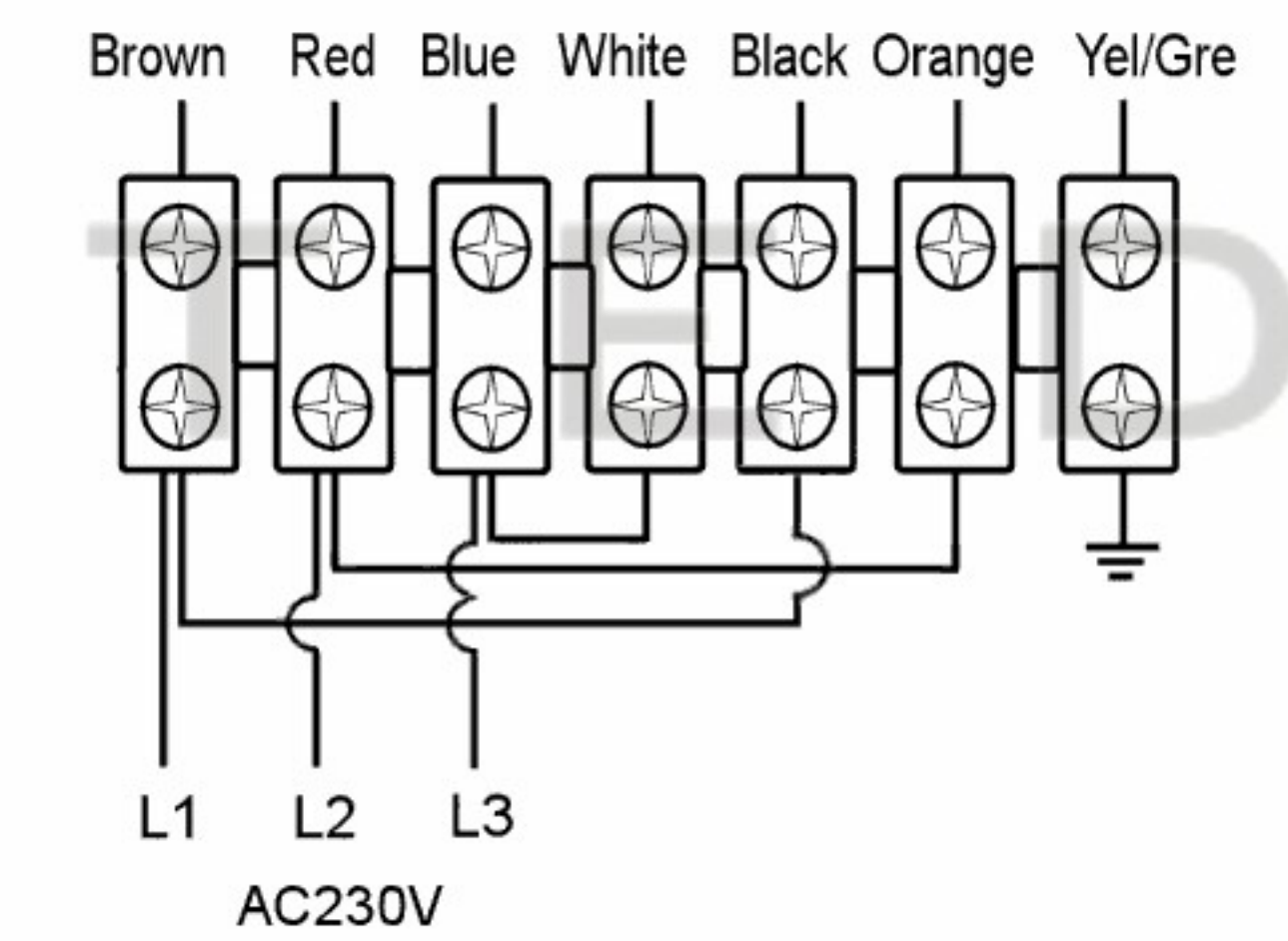
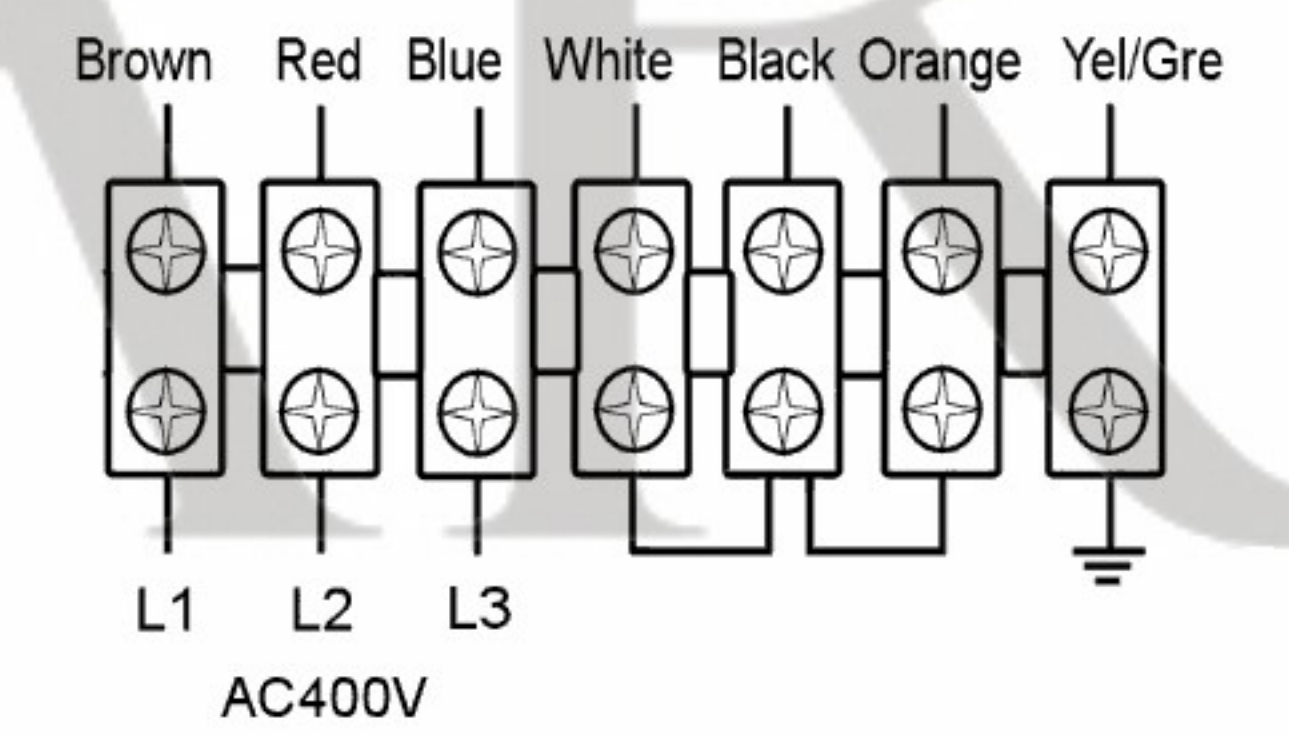

SPECIFICATION					
Motor	3Ph	Speed (RPM)	930	Bearings	Ball
Voltage (V)	380	Motor Protection	Th. Prot	Weight (Kg)	15
Frequency (Hz)	50	Insulation Class	B	Air Volume (M³/h)	8800
Power In/Out (W)	520	Protection Class	IP54	Noise Level (dBA)	72
Current (A)	1.25	Temp. Range	-30 +60	Capacitor (Mf)	N/A

**POLE STAR**  
PRODUCTS LIMITED

POLE STAR PRODUCTS LIMITED	
Product Code	
<b>GMA3-630S-1E-1</b>	
Projection Angle ± 3°	
	A4
	Scale:
	Sheet: 1 of