

**Accessories: DD12F (Mounting Feet)**

**Accessories: DDF12/9 (Mounting Flange)**

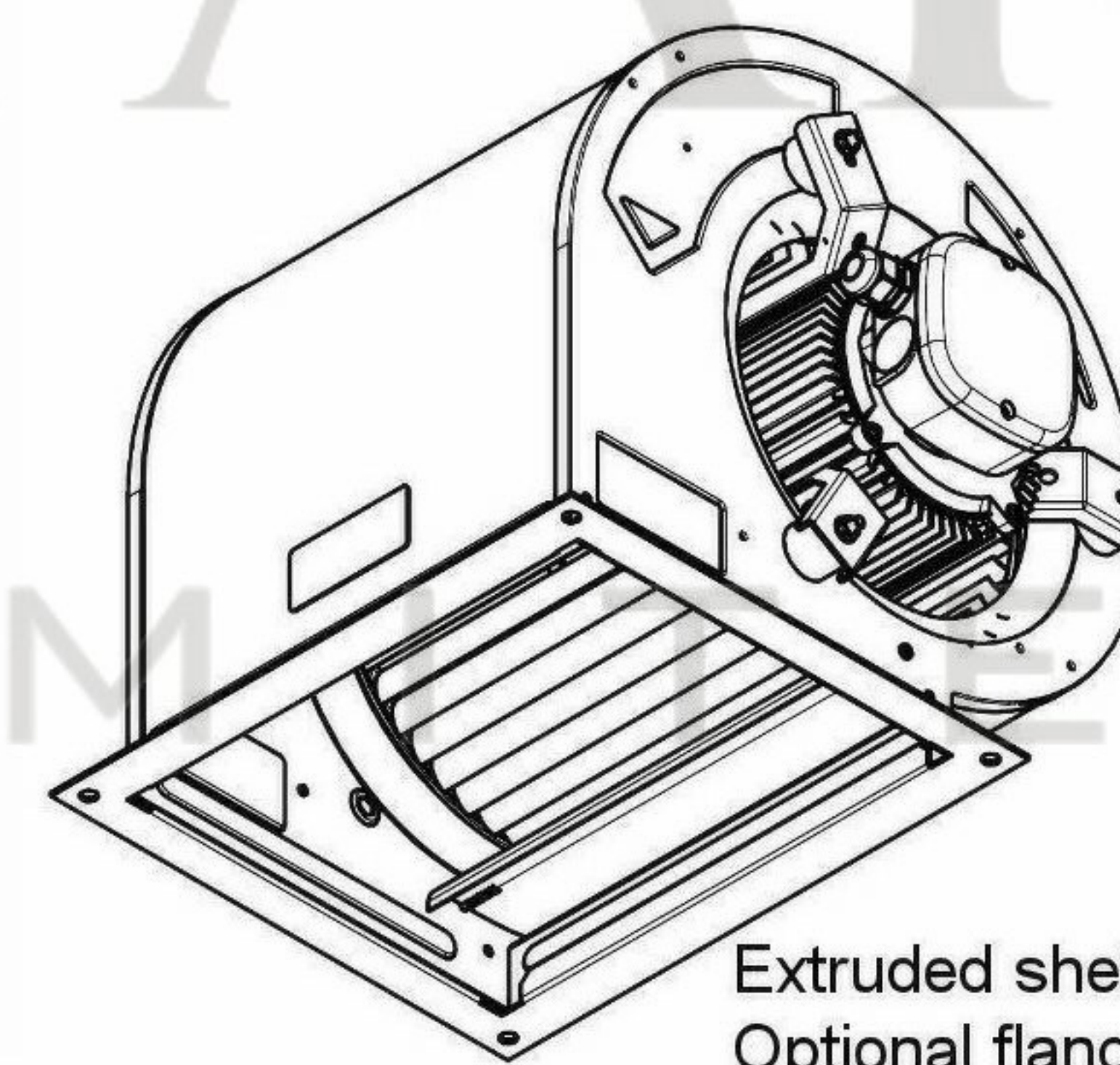
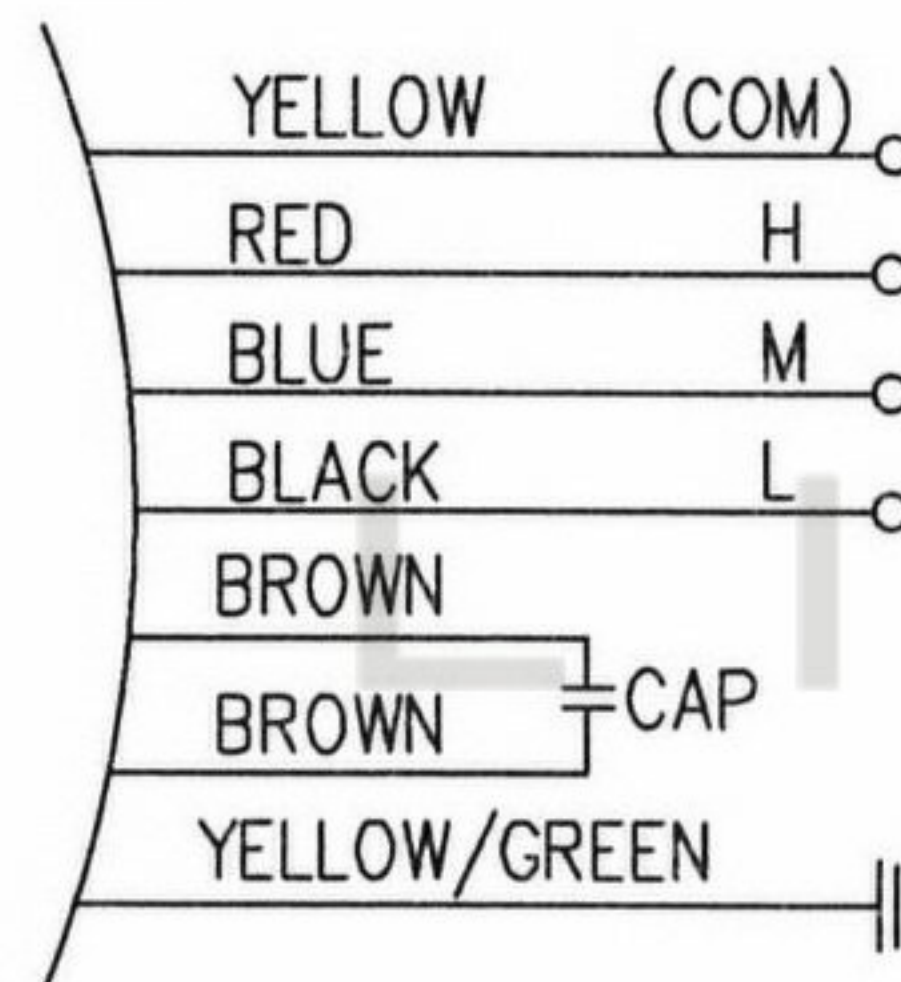
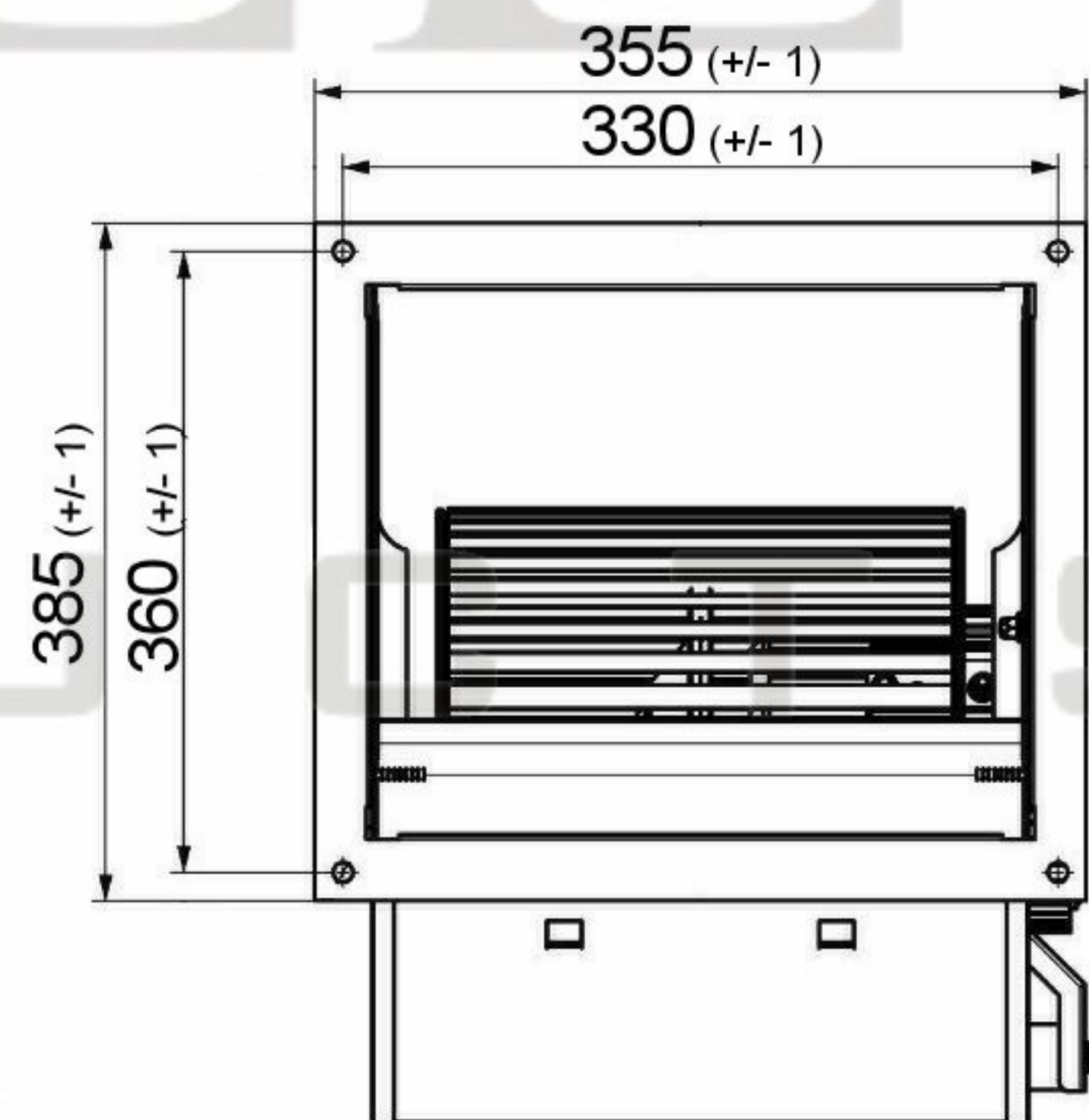
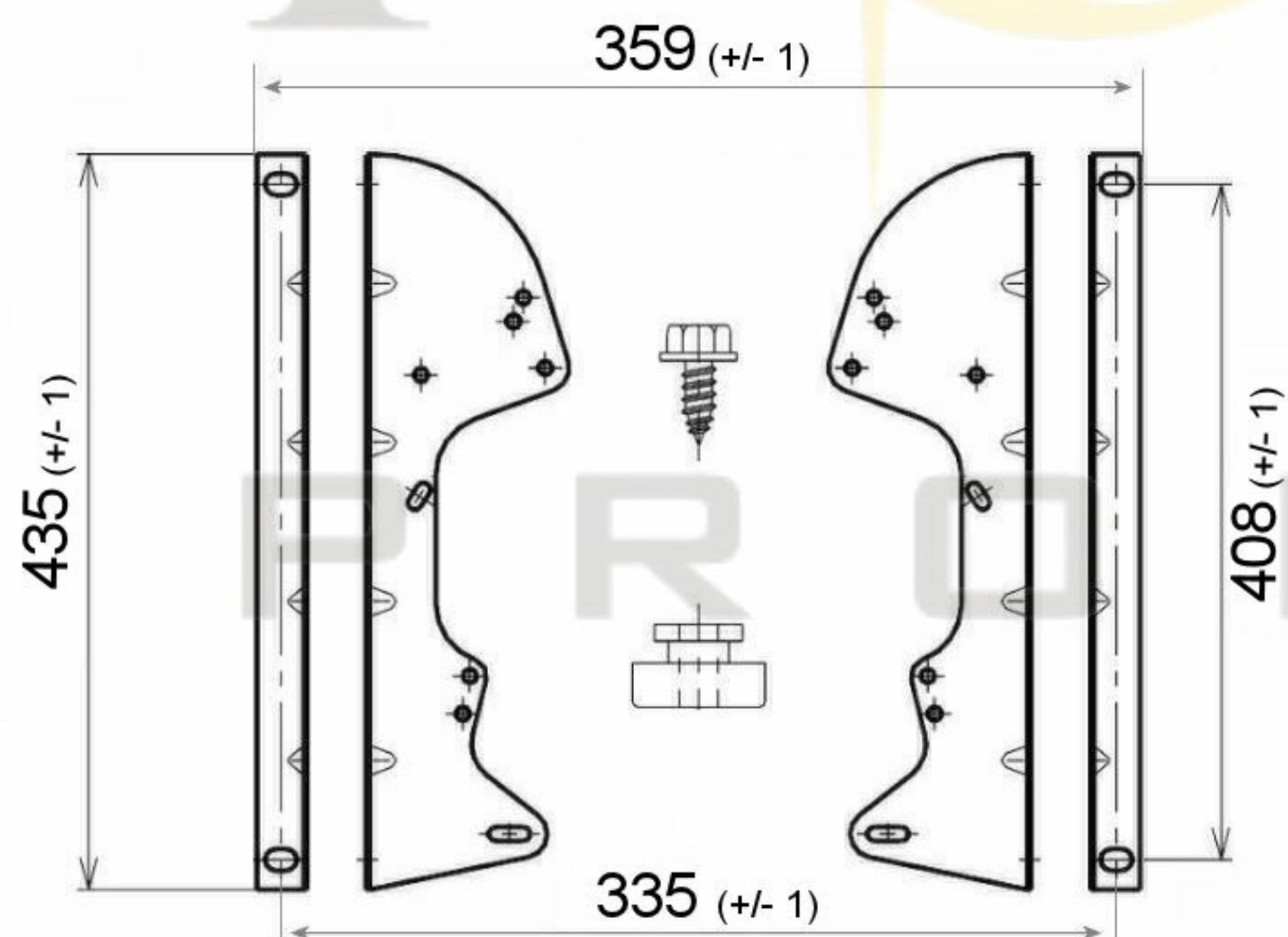

Extruded shell motor depicted  
Optional flange fitted

SPECIFICATION					
Motor	PSC	Speed (RPM)	1250	Bearings	Ball
Voltage (V)	230/240	Motor Protection	Th.Prot	Weight (Kg)	17.0
Frequency (Hz)	50/60	Insulation Class	B	Air Volume (M <sup>3</sup> /h)	
Power In/Out (W)	550	Protection Class	IP42	Noise Level (dBA)	
Current (A)	3.8	Capacitor (Mf)	15.0	Pressure (Pa)	78.45

**POLE STAR**  
PRODUCTS LIMITED

POLE STAR PRODUCTS LIMITED	
Product Code	
<b>DD12/9-F550/3V-1</b>	
Projection Angle	A4
± 3°	Scale:
	Sheet: 1 of