

Accessories: DD12F (Mounting Feet)

Accessories: DDF12/9 (Mounting Flange)

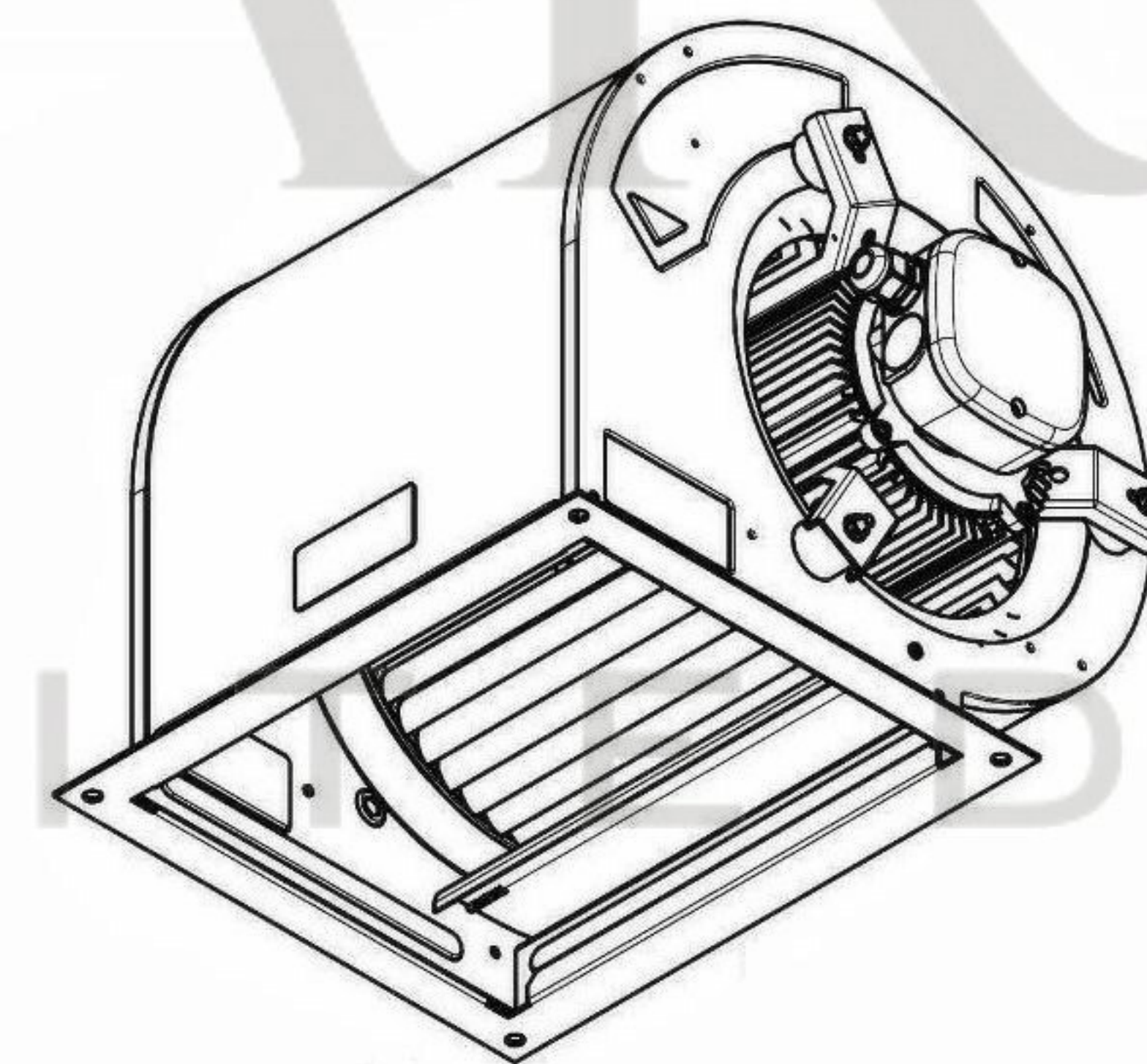
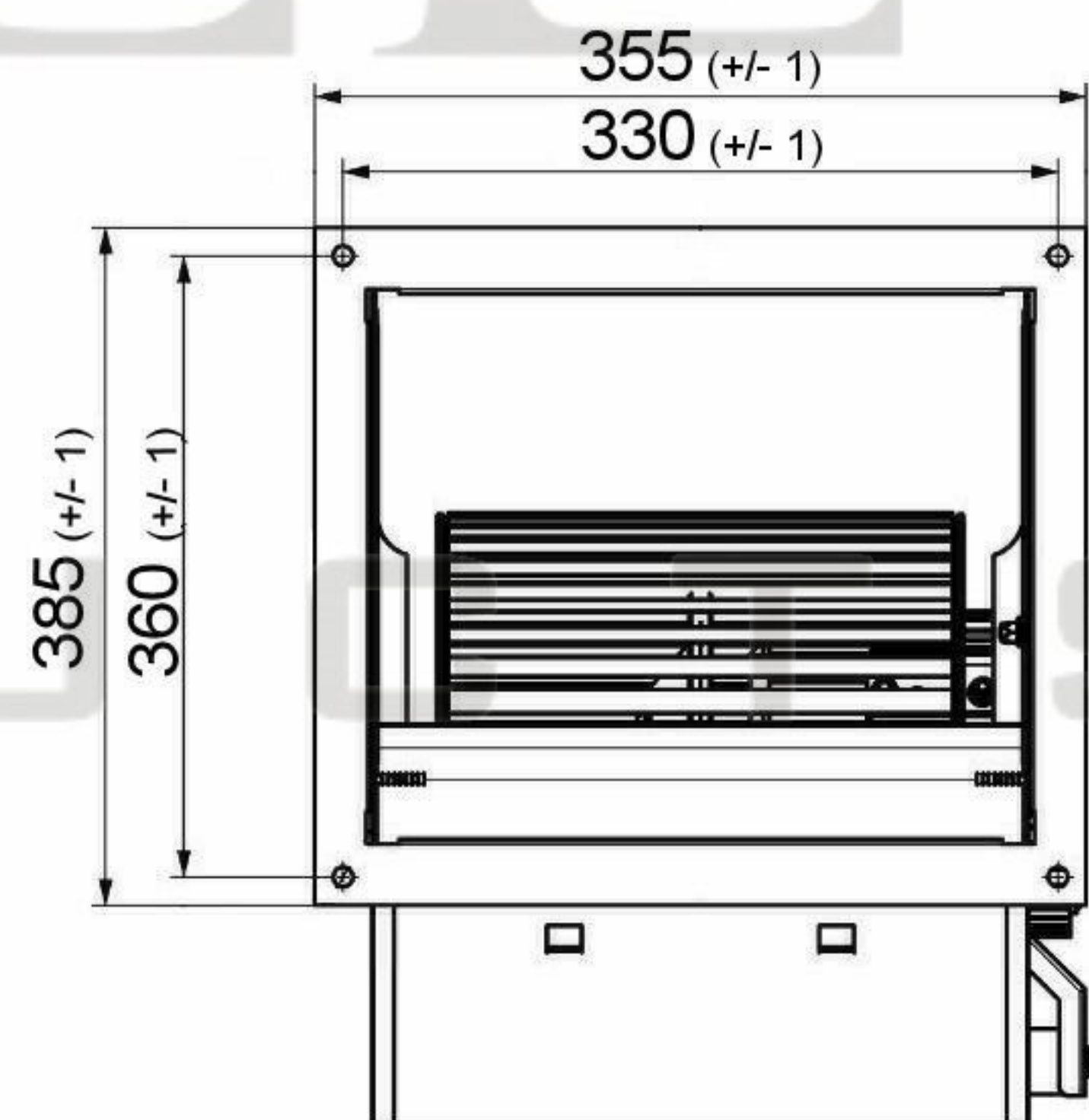
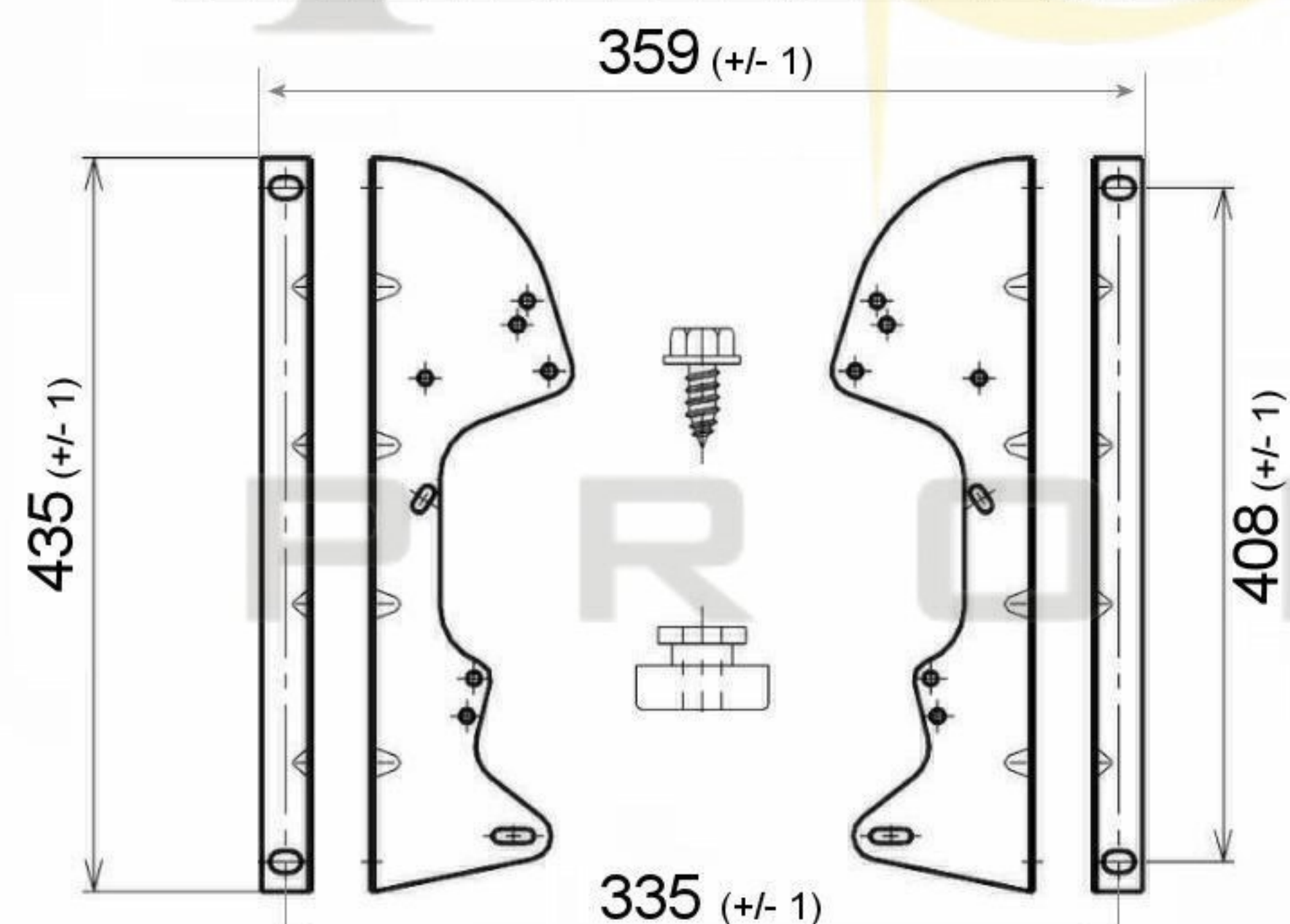

Optional flange fitted

SPECIFICATION					
Motor	PSC	Speed (RPM)	1250	Bearings	Ball
Voltage (V)	230/240	Motor Protection	Th.Prot	Weight (Kg)	17.0
Frequency (Hz)	50/60	Insulation Class	B	Air Volume (M ³ /h)	3900
Power In/Out (W)	550	Protection Class	IP42	Noise Level (dBA)	
Current (A)	3.8	Capacitor (Mf)	15.0	Pressure (Pa)	78.45

POLE STAR
PRODUCTS LIMITED

POLE STAR PRODUCTS LIMITED	
Product Code	DD12/9-F550/1V-1
Projection Angle	± 3°
	A4
	Scale:
	Sheet: 1 of