

<b>MOTOR</b>	White	
	White	Therm. Prot
	Yellow	N
	Red	H
	Blue	M
	Black	L
	Brown	Cap.
	Brown	Cap.
YELL./GREEN		

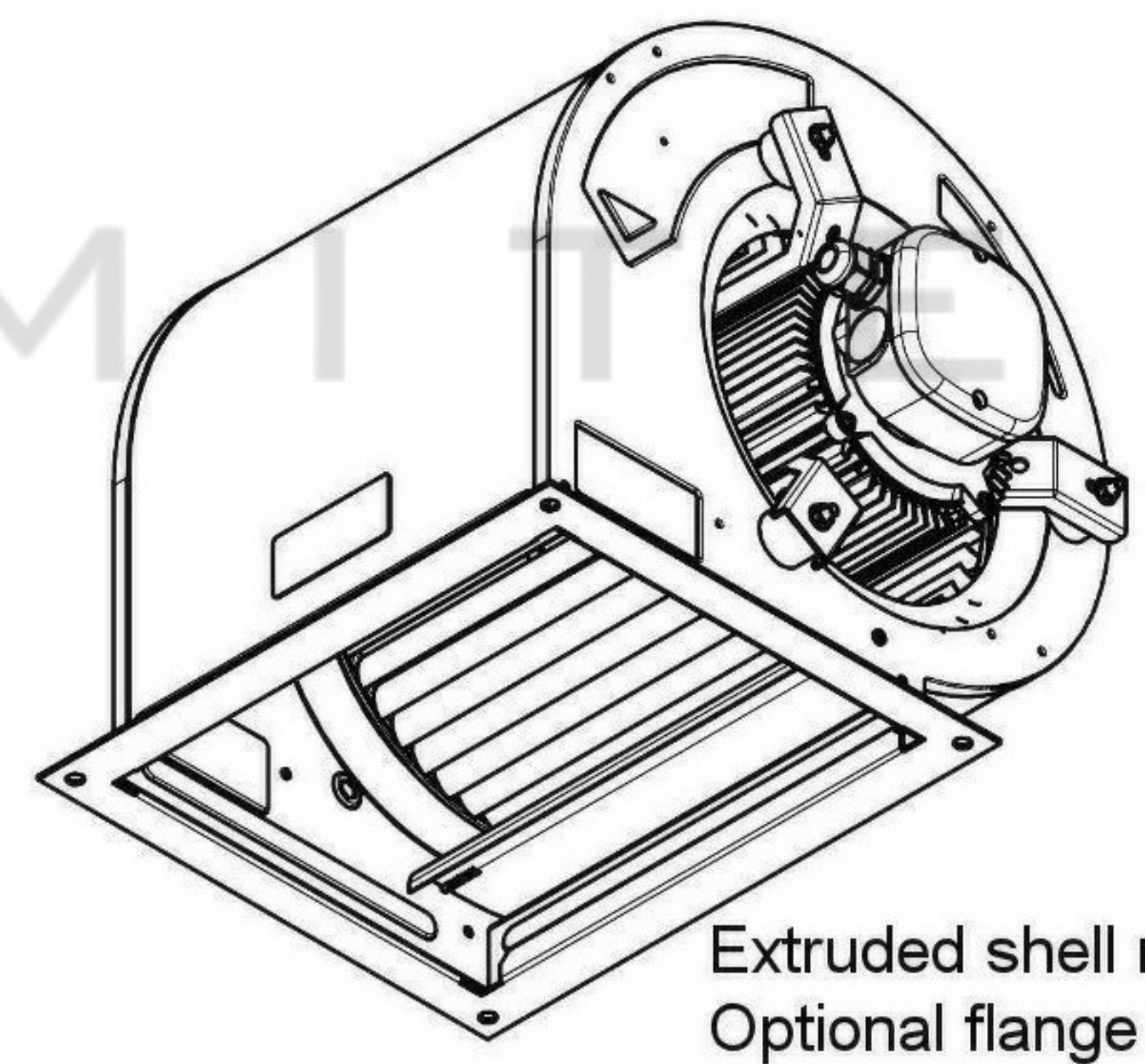

Extruded shell motor depicted  
Optional flange fitted

SPECIFICATION					
Motor	PSC	Speed (RPM)	1300	Bearings	BALL
Voltage (V)	230/240	Motor Protection	Th. Prot.	Weight (Kg)	
Frequency (Hz)	50/60	Insulation Class	B	Air Volume (M <sup>3</sup> /h)	
Power In/Out (W)	600/370	Protection Class	IP22	Noise Level (dBA)	
Current (A)	3.0	Temp. Range		Capacitor (Mf)	12.5

**POLE STAR**  
PRODUCTS LIMITED

POLE STAR PRODUCTS LIMITED	
Product Code	DD10/10-F370/3V-1
Projection Angle	± 3°
	A4
	Scale: Sheet: 1 of