

Drawing Version	01
Drawn by	AJC
Date	03/22

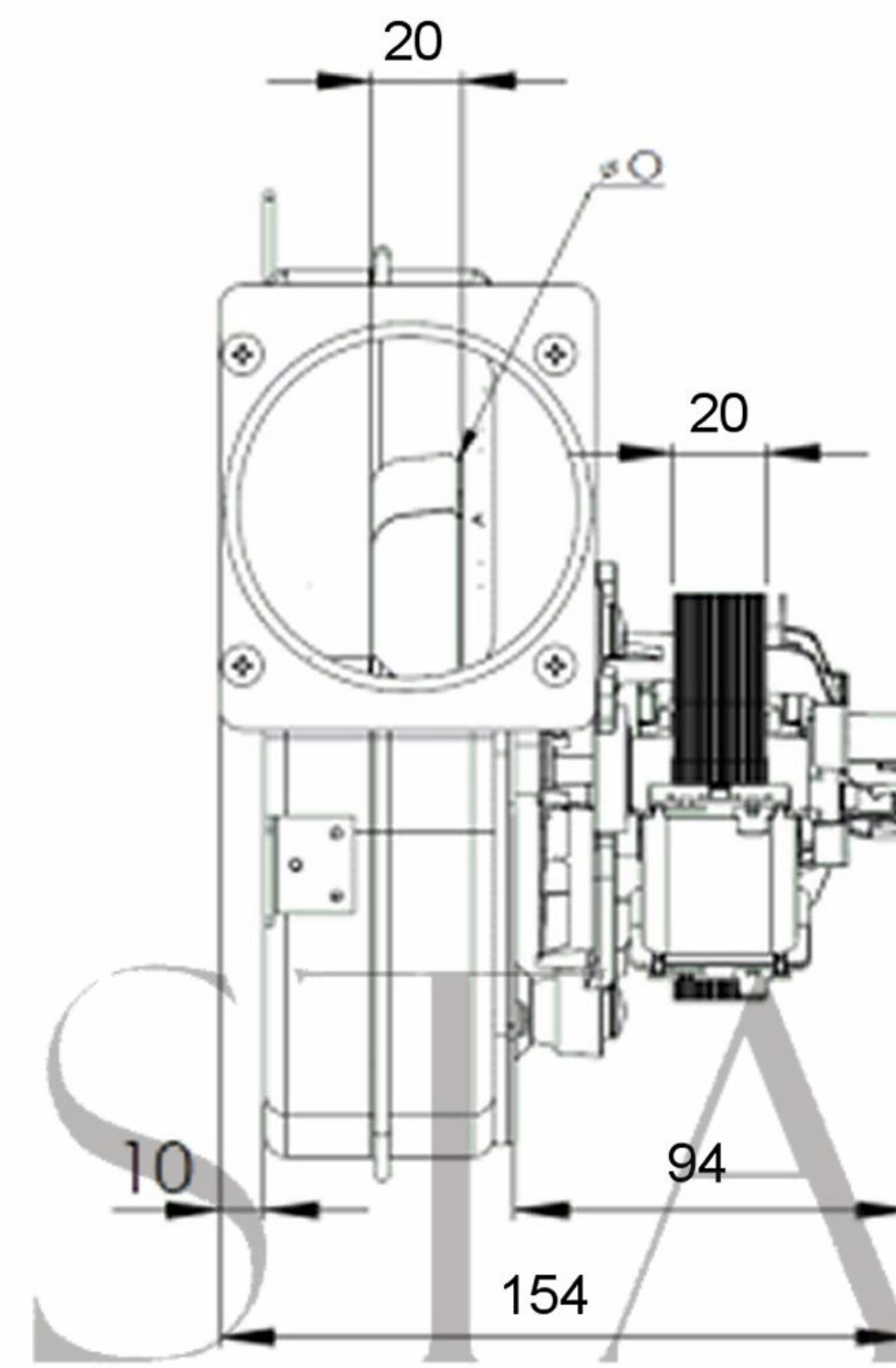

POLE STAR PRODUCTS LIMITED

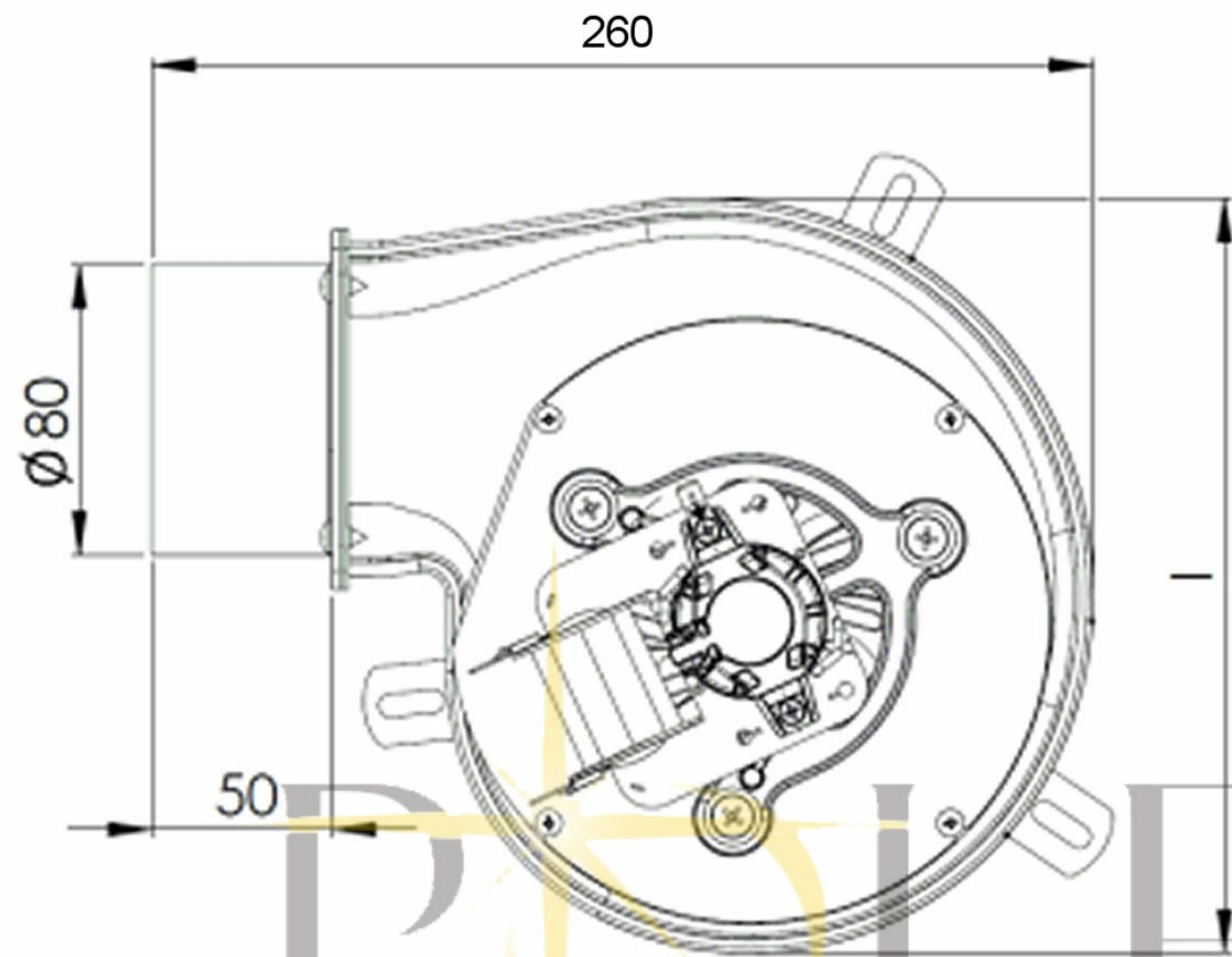
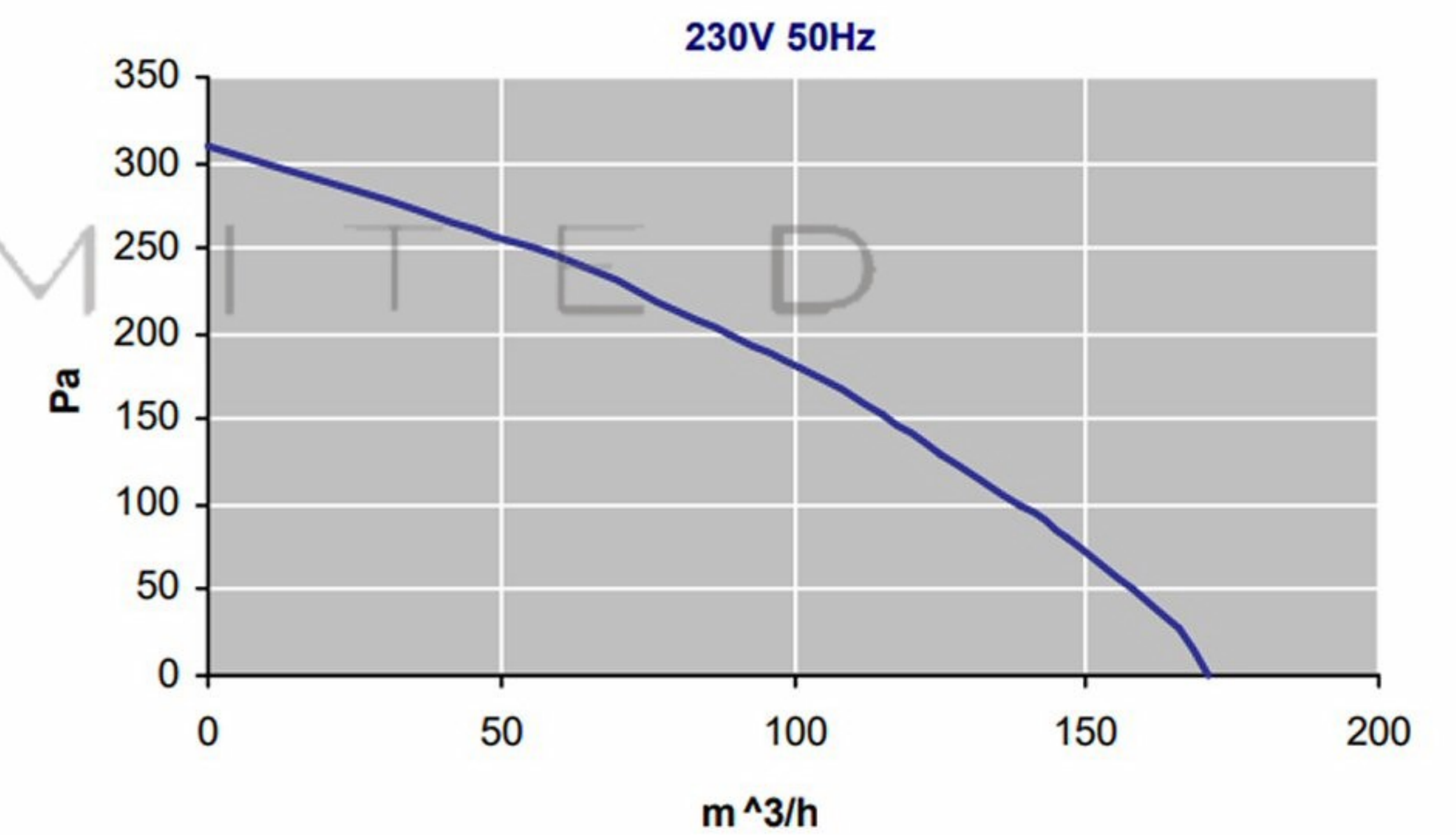

SPECIFICATION					
Motor	S.P.	Speed (RPM)	2600	Bearings	Ball
Voltage (V)	230	Motor Protection	TH Prot	Pressure (PA)	
Frequency (Hz)	50	Insulation Class	H	Air Volume (M³/h)	170
Power In/Out (W)	40	Protection Class	IP00	Noise Level (dBA)	300
Current (A)	0.35	Temp. Range	0-90	Capacitor (MF)	n/a

**POLE STAR**  
PRODUCTS LIMITED

POLE STAR PRODUCTS LIMITED	
Product Code	
<b>ESB1-150-20-2</b>	
Projection	A4
Angle	Scale:
± 3°	Sheet: 1 of

