

Drawing Version	01
Drawn by	AJC
Date	2/22

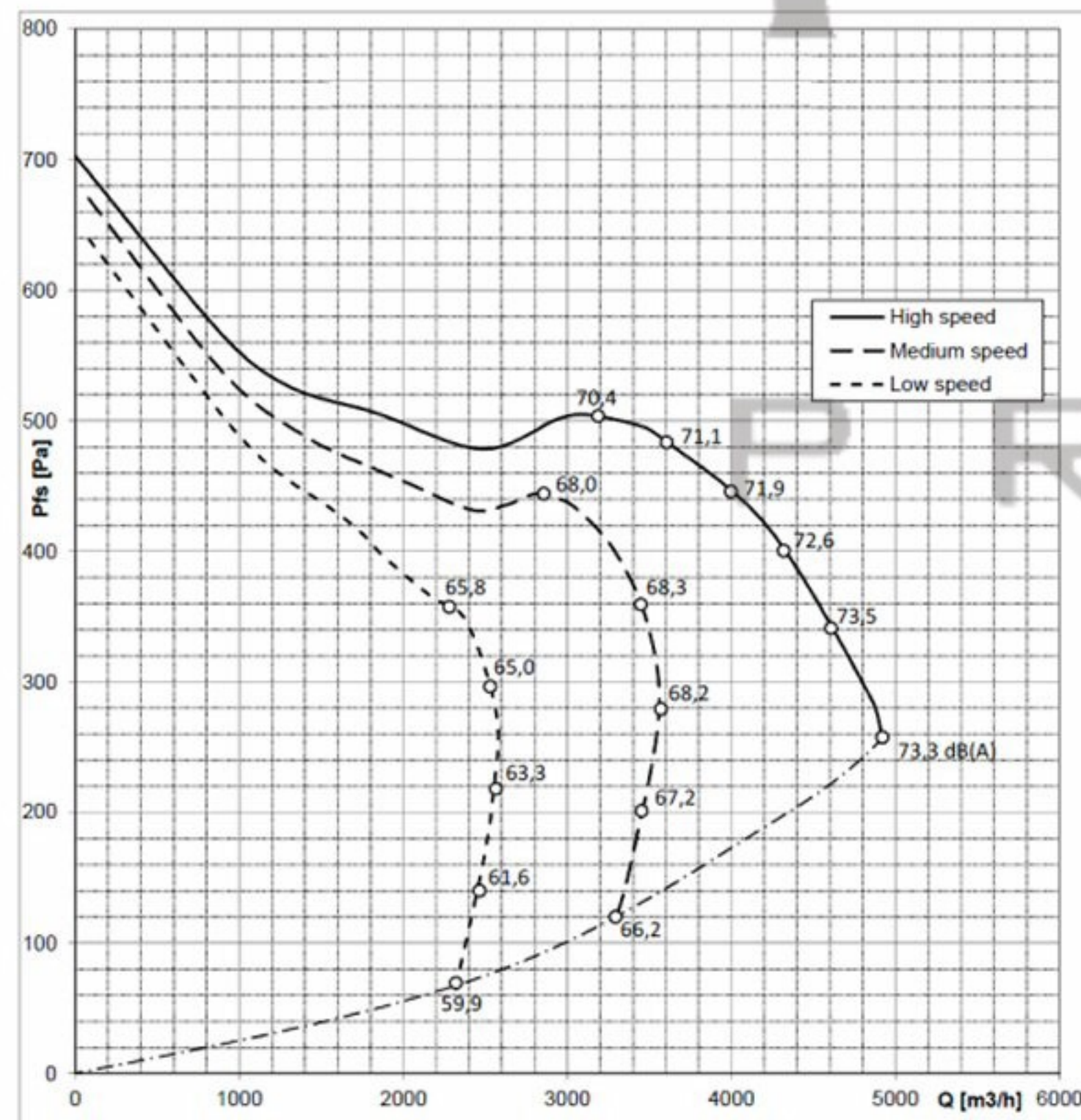
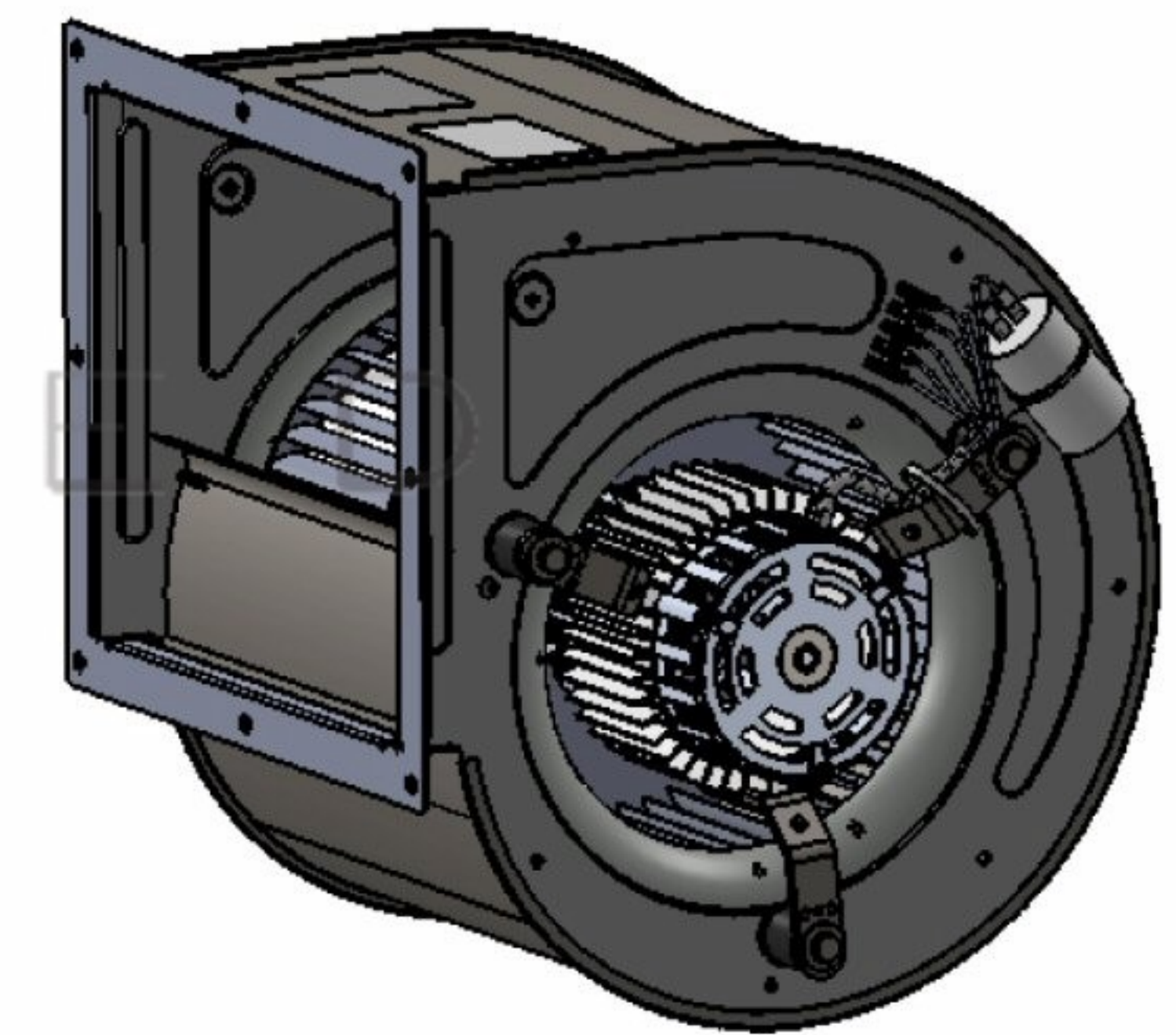
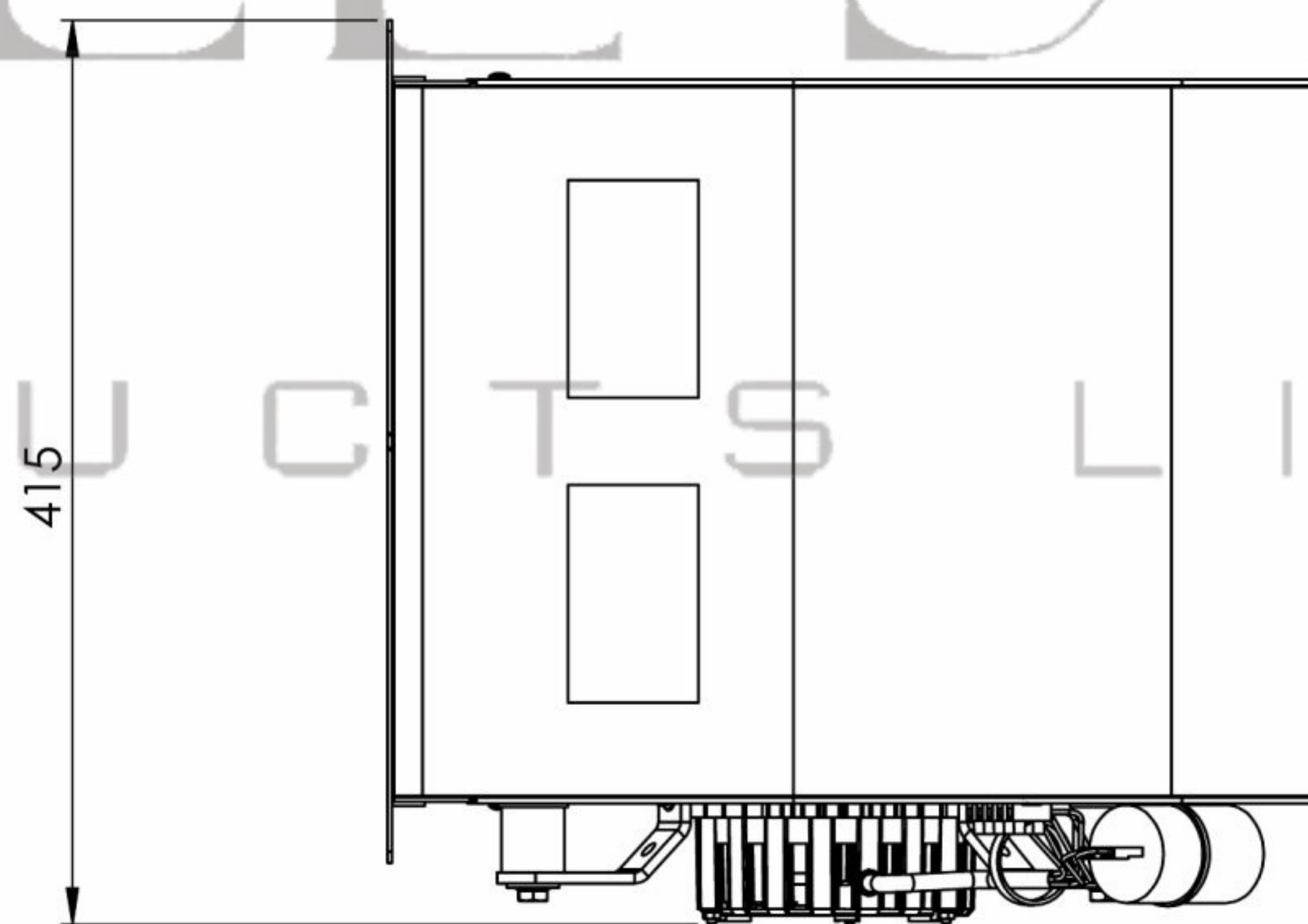
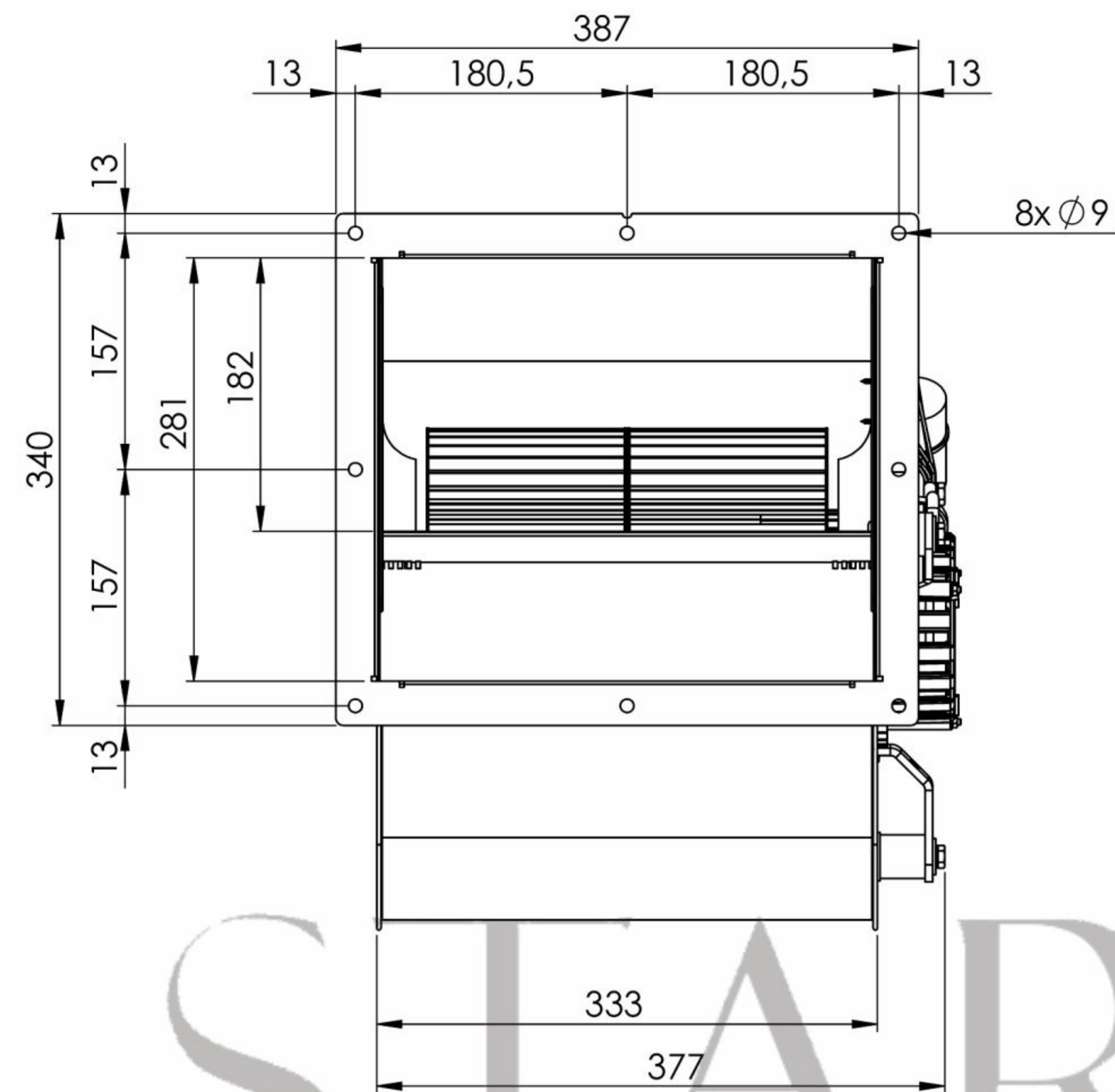
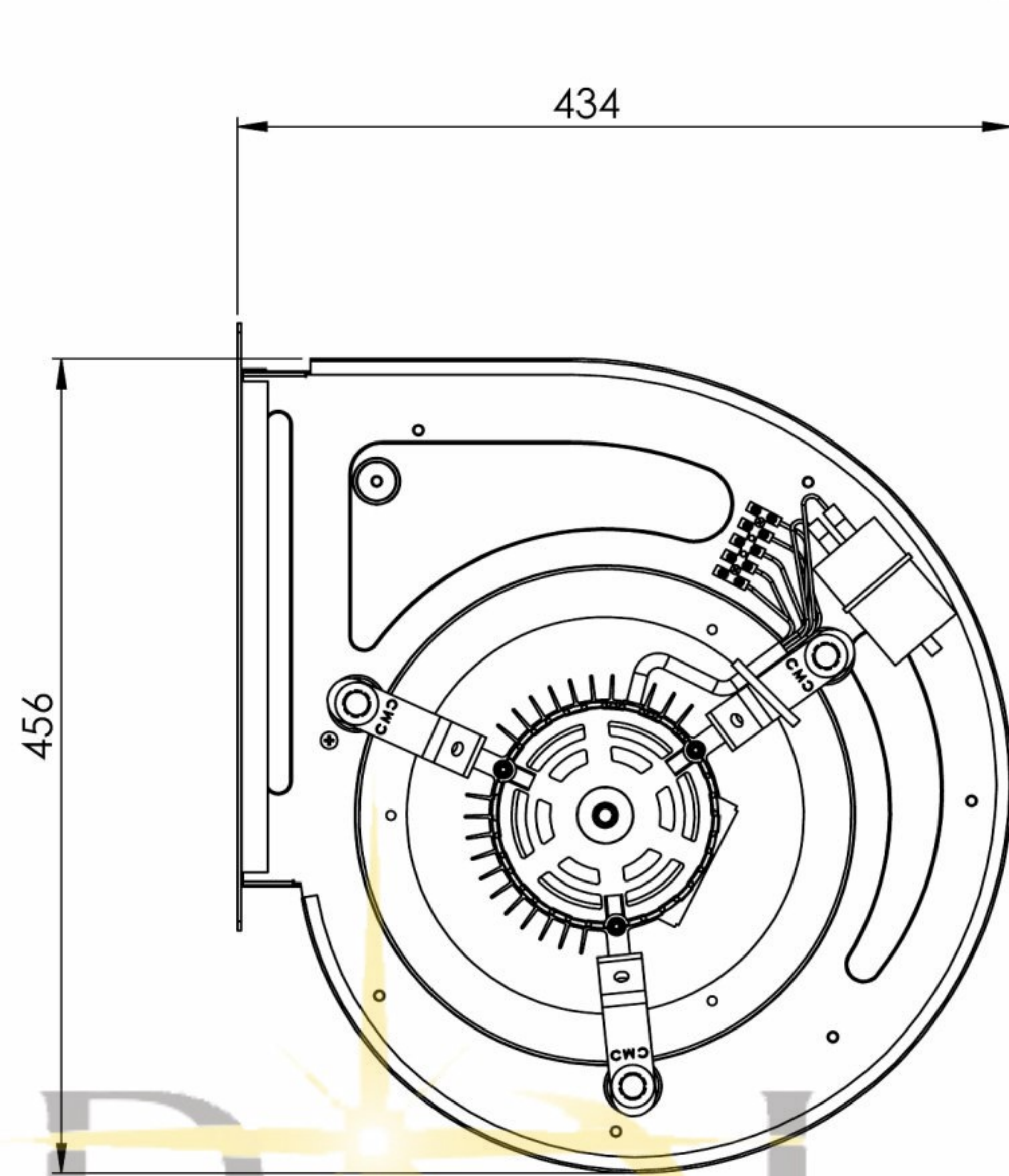

SPECIFICATION

Motor	1ph	Speed (RPM)	4 Pole	Bearings	Ball
Voltage (V)	230	Motor Protection	Th.Prot	ErP 2015	Pass
Frequency (Hz)	50	Insulation Class	F	Air Volume (M³/h)	4900
Power In/Out (W)	750	Protection Class	IP20	Noise Level (dBA)	
Current (A)	9.6	Speeds	3	Pressure (Pa)	

POLE STAR
PRODUCTS LIMITED

POLE STAR PRODUCTS LIMITED

Product Code
DD10/10-F750/3V-1

Projection
Angle
± 3°

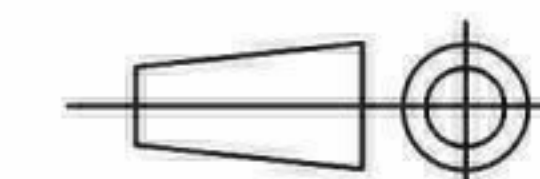

A4
Scale:
Sheet: 1 of